

# BENCHMARK PLUS



## LED STRASSENLEUCHE

# SLP65

Kunststoffgehäuse  
Hohe Energieeffizienz

### ANWENDUNGSBEREICHE

Stadtstraßen, Verbindungsstraßen, Kreuzungen, Parkplätze,  
Gewerbe- und Industriearale, etc.



RoHSII

LED



IP66

IK09



50%  
DIM

DALI

## SPEZIFIKATIONEN

Lichtleistung	2770 - 7500 Lumen
Anschlussleistung	17 - 50 Watt
Spannung / Hertz	220-240 V / 50-60 Hz
Überspannungsschutz	10 kA
Lichtfarbe	4000 Kelvin (andere optional)
Farbwiedergabe	CRI $\geq$ 70 ( $\geq$ 80 optional)
Umgebungstemperatur	-25°C / +45°C
LED-Treiber	Tridonic, Philips
Material	Polymer, PP-30% Glasfaserverstärkt
Optik	PMMA Linsen / Asymmetrisch
Zertifikate	CE
Schutzart	IP66
Schutzklasse	SK I (SK II optional)
Stoßfestigkeit	IK09
Lebensdauer	bis zu 50.000 Stunden
Mastanbindung	Ø 60 mm schwenkbar
Garantie	5 Jahre
Optional	Andere Lichtfarbe Schutzklasse II Andere Gehäusefarbe

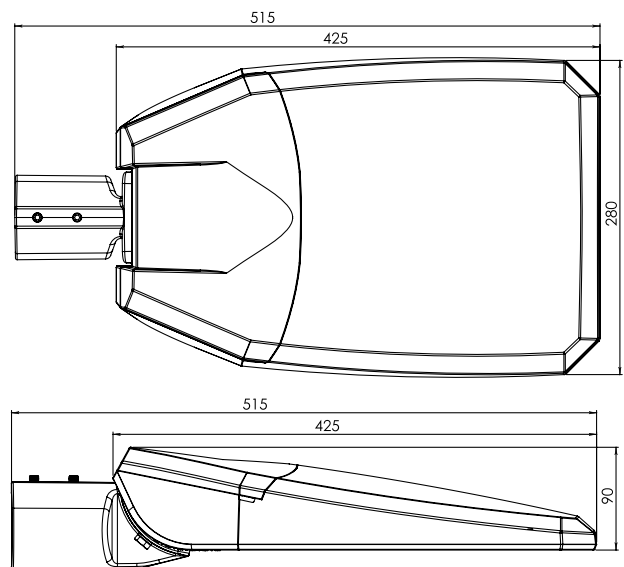

# LEISTUNGSTABELLE

Gehäuse	Watt	Lumen
<b>SLP65</b>	17	2770
Abmessungen: 425 x 280 x 90 mm	25	4000
Gewicht: 2,9 kg	36	5680
	42	6426
	50	7500

# OPTIKEN

